

For a world with clean water

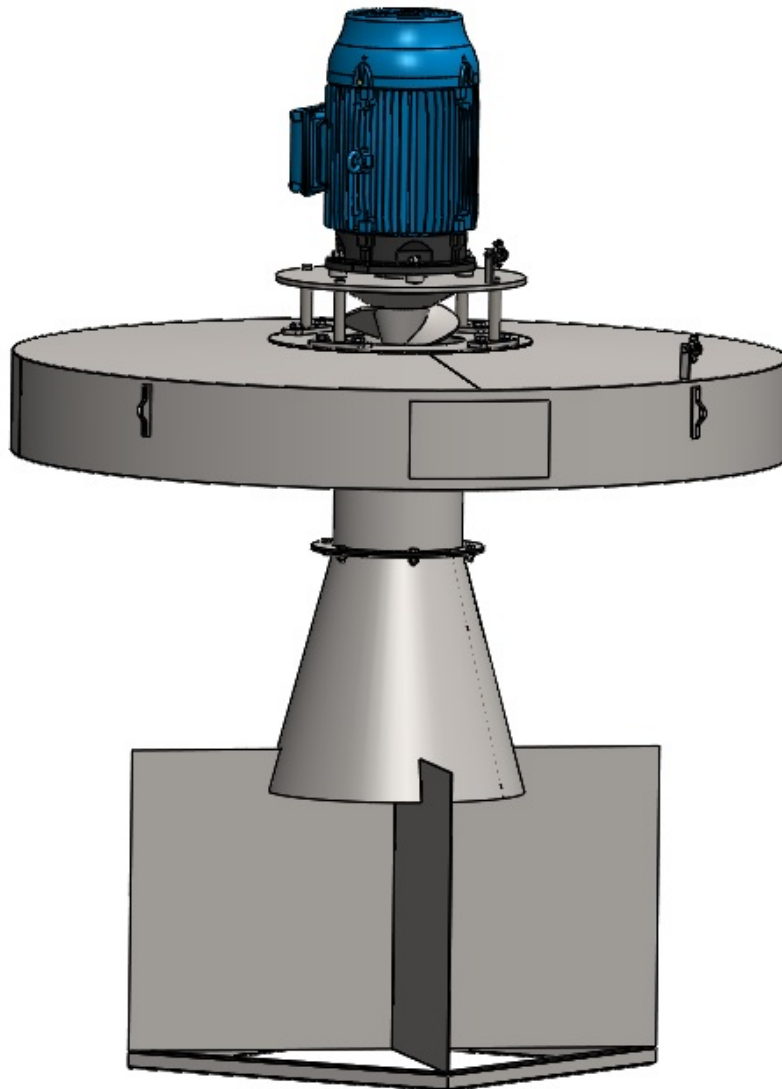

ATB - HSA

Installation/Operating Instructions

!!! IMPORTANT !!!

PRIOR TO USING THE UNIT

- Anybody involved MUST imperatively read and fully understand the unit's O&M manual, including the drive O&M manual.
- It is most important that the O&M manuals remain with the operator for future reference.

GENERAL

- No foreign objects such as hard materials, plastic bags, etc... are allowed in the basins. These objects can cause extensive damage and/or for example create unbalance to the impeller.
- In case of DOL start: Always use a soft starter for motors of 4 KW and more (see chapter 4.4.3)
- **Because of safety reasons it is absolutely forbidden to stand on the float!**

START-UP

- Please check all screwed connections (Motor, Flange/Power section, Cone-Cross) on right tightness! Use a dynamometric key. Tightening torque is shown in table 1 (chapter 4).
- Please check the correct rotational direction of the unit.

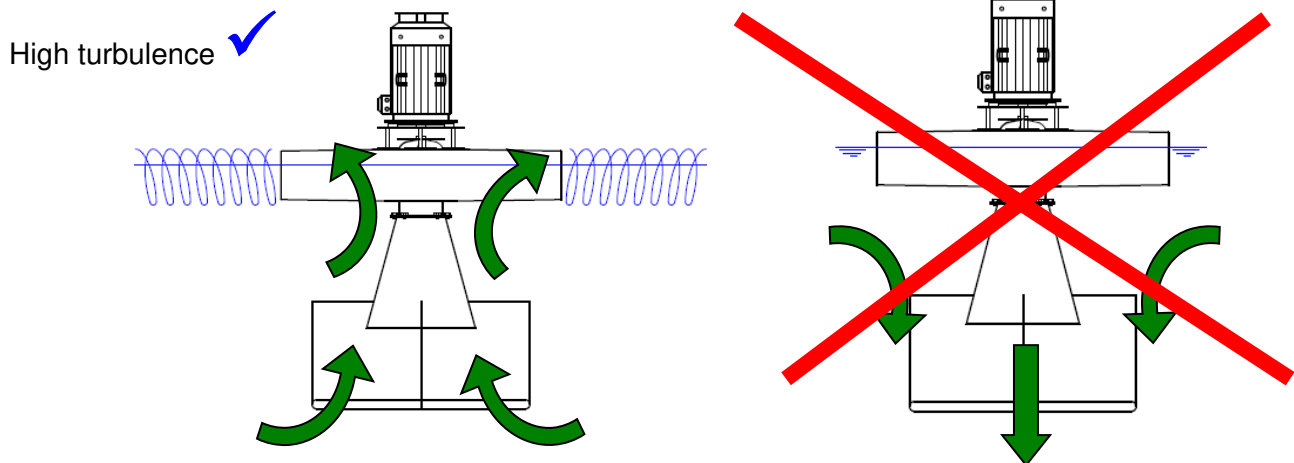

- The motor may never be covered by a foam layer, neither partly nor completely.

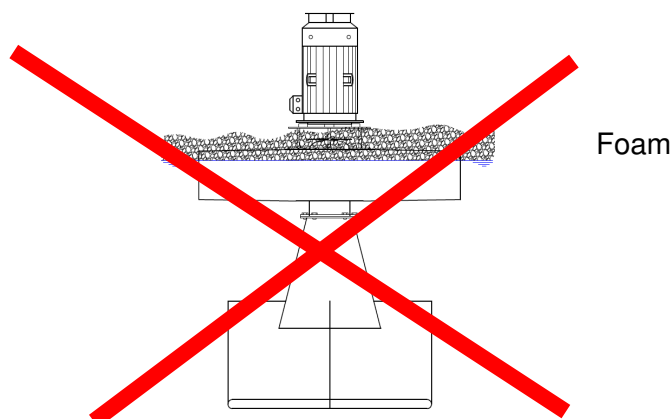

Content

1. Safety regulations	4
2. Product overview	6
2.1. Description	6
2.2. Working principle	6
3. Receiving and handling	7
3.1. Receiving and acceptance	7
3.2. Handling (loading/unloading)	7
4. Assembly and installation	9
4.1. Assembly of aerator unit	9
4.1.1. Assembly of power section and float in case the unit is delivered in 3 parts	10
4.1.2. Assembly of the unit in case it is delivered in 2 parts	10
4.2. Overview of mooring systems	11
4.2.1. Mooring with cables	11
4.2.2. Hinged arm	12
4.2.3. Vertical guiding system	15
4.3. Installation	16
4.3.1. Mounting sequence for installation with mooring cables	16
4.3.2. Mounting sequence for hinged arm system	19
4.3.3. Mounting sequence for the vertical guiding system	20
4.4. Electrical cable and wiring instructions	22
4.4.1. General wiring instructions	22
4.4.2. Position of the electrical cable	23
4.4.3. Electrical connection diagrams	26
4.5. Start up	31
5. Maintenance	33
6. Storage	35
6.1. Temporary storage (= 1 up to 4 weeks)	35
6.2. Long term storage (= more than a month)	35
ENCLOSURE I: Part list HSA aerator with standard stabilization cross	36
ENCLOSURE II: Mooring cables and accessories	37
ENCLOSURE III: General data	38
ENCLOSURE IV: Declaration of conformity	39
ENCLOSURE V: Maintenance sheet	40
ENCLOSURE VI: Motor O&M manual	41

1. Safety regulations



We will mention, in this chapter, the major kind of risks and dangers that might occur, and the safety precautions to be taken.

- As mentioned in our declaration of conformity and in the warranty regulation, our aerator can only be used when the installation, into which they need to be incorporated, is declared conform to the Machinery Directive.
- If ATB did not deliver an explosion proof motor, it is forbidden to use the equipment in areas where explosive gases might be present.
- At the moment of receipt and acceptance of the goods, you must always check that the **HELICAL IMPELLER** can be rotated manually. Always be careful not to put a hand between the **HELICAL IMPELLER** and the volute.
- Because of the weight of the goods, persons who are not directly involved should be kept out of the handling area.
- Prior to the installation the lifting equipment must be inspected by an official authority, and found suitable for the job, to allow safe loading, unloading and positioning.
- The complete electrical installation has to be designed in accordance with the European standard EN 60204 concerning the electrical equipment of machinery, to NEMA, IEC or any other locally valid directives concerning the electrical installation and connection of machinery.
- Starting the aerator on dry land, to check the balance of the motor and **HELICAL IMPELLER** or to do a last greasing, should not be done without taking radical safety provisions and has to be performed by a qualified person. Should any abnormality occur, the aerator must be switched off immediately.
- During the installation of the aerator, all necessary personal protection equipment has to be at the disposal of all persons involved in the assembly and installation of the equipment.



It is essential to check that the safety switch of the unit that needs to be installed, and also of all other units located in the basin where the unit needs to be installed, has been switched off and locked in this position during all work on the electrical installation, during maintenance or repairs, and during installation.



As a safety precaution and also to prevent the unit from tipping, it is absolutely forbidden to stand on the unit. It is possible to reach the aerator by using a boat as shown on drawing 1: "Reaching the unit by using a boat."

- During any intervention on the electrical installation, maintenance and/or repairs of the unit, a second person has to be present to verify the safe intervention and eventually assist.

ATB WATER GmbH is not responsible for any kind of incidents.

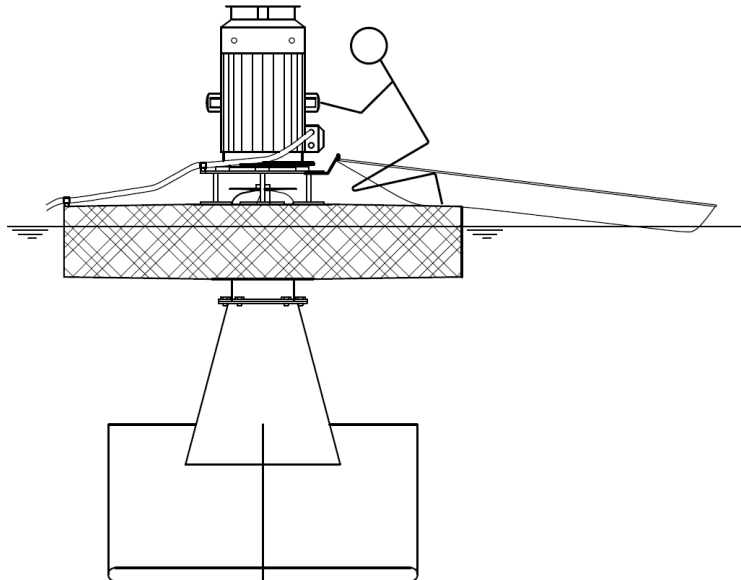

Drawing 1: Reaching the unit by use of a boat

During the start up of the aerator nobody may stand be in a boat near the aerator.

Make sure that all safety precautions are taken to make sure that nobody can fall into the water.

2. Product overview

2.1. Description

The HSA floatable surface aerator generally consists of a top mounted electrical motor, which drives a helical impeller.

The electrical motor is mounted on a flange support, which at its turn is mounted on the stainless steel float.

A cone (possibly equipped with crossplates) is mounted below the float, at the cylindrical volute tube and enables an ideal flow into the volute and impeller.

The HSA offers following advantages:

- low investment cost for the complete installation
- simple and quick installation
- high performance in oxygen transfer
- intensive mixing
- no need to empty the tank, neither for the installation, nor for the maintenance of the equipment
- excellent reliability

2.2. Working principle

The HSA functions as an open pump. The mixed liquor of wastewater and activated sludge is aspirated via the suction pipe. The helical impeller pumps the liquid axially up through the cylindrical volute, bends the liquid flow from axial to radial, and ensures that maximum kinetic energy is transferred to the water surface.

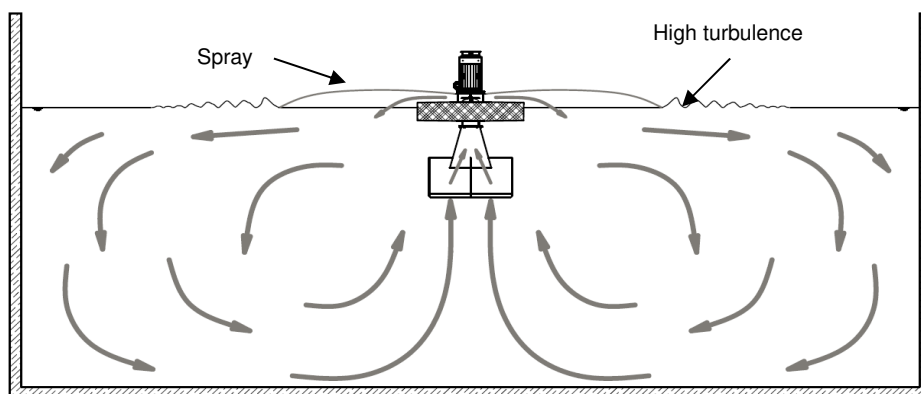

Drawing 2: Working principle

Whilst transferring the maximum kinetic energy to the water, the helical impeller achieves a high performance in pumping and oxygen transfer. Due to the design of the impeller, the forces on the bearings are very low, so standard bearings can be used.

3. Receiving and handling

3.1. Receiving and acceptance

- Check the goods for visible damage before unloading.
- Check if the **HELICAL IMPELLER** can be rotated manually.

If you have any remarks, please note them on the forwarding documents, and contact ATB immediately.

The unit is forwarded in 2 or 3 parts:

- Power section (= motor, flange support and **HELICAL IMPELLER**)
- Float
- Cone (eventually equipped with crossplates)

In case of 2 parts, float and power section are pre assembled.

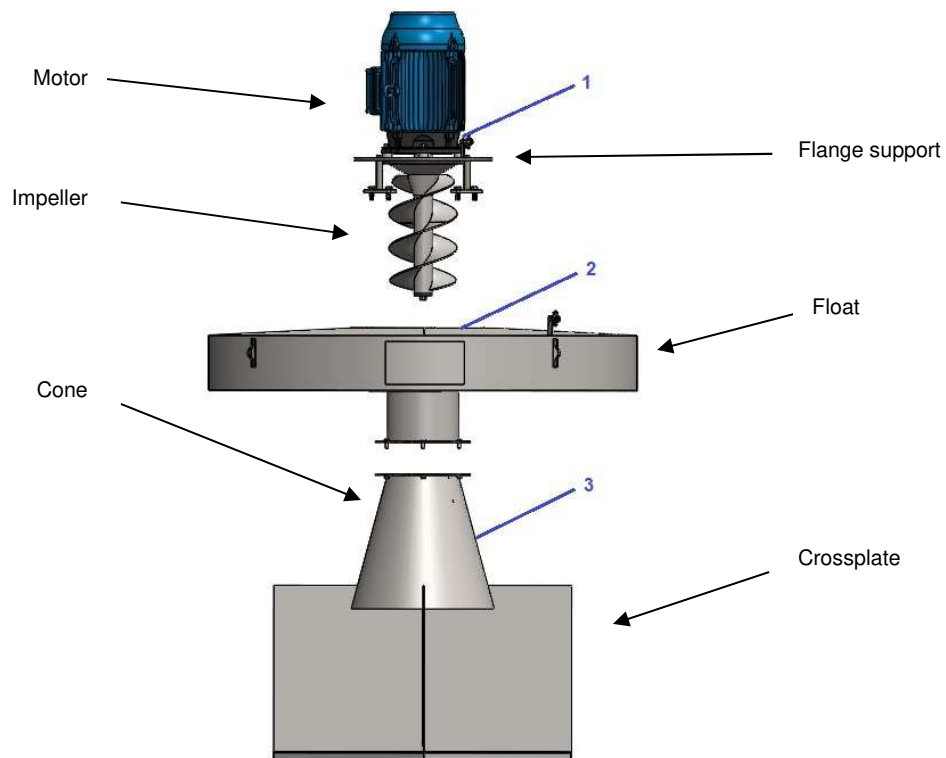

Drawing 3: Major parts for transport

3.2. Handling (loading/unloading)

Be careful when handling this type of heavy, precision equipment to avoid damage to it or other equipment, or injure any person involved. Persons that are not directly involved in loading/unloading should be kept out of the handling area.

Only the eyes mounted on the motor, and the special lifting brackets mounted on the flange support, can be used for lifting respectively the power section and the complete unit. Damage to the unit may occur if incorrect lifting practices are used.

Installation/Operating Instructions ATB - HSA

The lifting equipment used, should have been inspected and approved by an official authority prior to unloading the truck in order to allow safe handling.



CAUTION:

Never lift with only one motor eye or with the mooring anchors on the float!

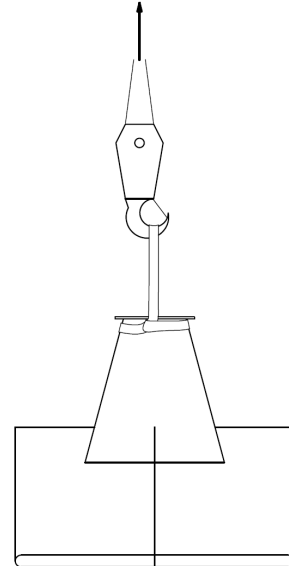
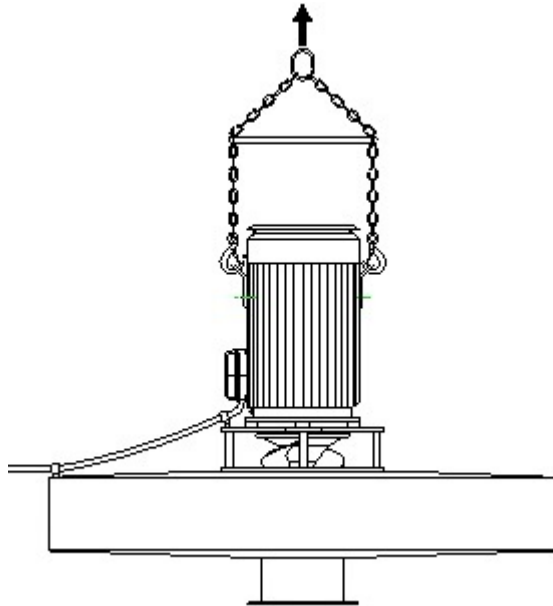

Drawing 4: How to lift the unit

4. Assembly and installation



IMPORTANT NOTE:

Apply anti-seize grease (f.ex. Mi-setral-7N) on all bolts prior to assembly.



IMPORTANT NOTE:

All screwed connections (Motor, Flange/Power section, Cone-Cross) have to be tightened by using a dynamometric key. Tightening torque is shown in table 1 (see below).

If the unit is supplied in 3 parts, use the delivered Loctite when assembling the power section to the float.

Screw	Tightening torque [Nm]
M 8	21,4
M 10	44
M 12	74
M 14	119
M 16	183
M 18	260
M 20	370
M 22	488
M 24	608
M 27	728
M 30	848

Table 1: Tightening torque

4.1. Assembly of aerator unit

As mentioned earlier, the unit is forwarded in 2 or 3 parts:

- power section (= motor, flange support and **HELICAL IMPELLER**)
- float (already assembled with power section in case of 2 parts)
- cone (possibly equipped with crossplates)

The unit should be assembled on flat and stable ground. It is mandatory to use lifting hooks, which have safety locks.



IMPORTANT NOTE:

The assembled surface aerator can be placed on the bottom of the basin during installation. It must be secured against tipping with the help of the guiding system. If this is not possible, the aerator must be secured by a support structure made by the customer.

Permanent set up of the assembled aerator on the bottom of the basin or permanent storage in this condition is not permitted. If, despite this, the aerator is to be stored or set up in the assembled state for a longer period of time, the weight of the float/ motor must be relieved from the intake cone/cone cross by means of a suitable support structure provided by the customer.

4.1.1. Assembly of power section and float in case the unit is delivered in 3 parts

- Carefully lift the power section (which is generally transported in horizontal position) by means of the motor eye, to bring it in vertical position. The lifting eyes on the motor on which the attachment will be made must be connected diagonally.
- **Pay special attention to the impeller, so that it is not touched/hit during handling.**
- Slide the impeller slowly and vertically down into the volute of the float, and position the flange support such that the positioning stud on the top flange of the float coincides with the recess made in one of the connection flanges of the flange support.
- Insert the fixation bolts but don't turn them tight yet.
- Verify if the impeller can turn free into the volute, without touching.
- If so, tighten the bolts, and afterwards recheck if the impeller turns freely.



IMPORTANT NOTE:

Every power section, float, and cone/cross has a serial number. Make sure not to mix the parts of different units, especially not the power sections and floats, as this might result in assembly and operation problems.

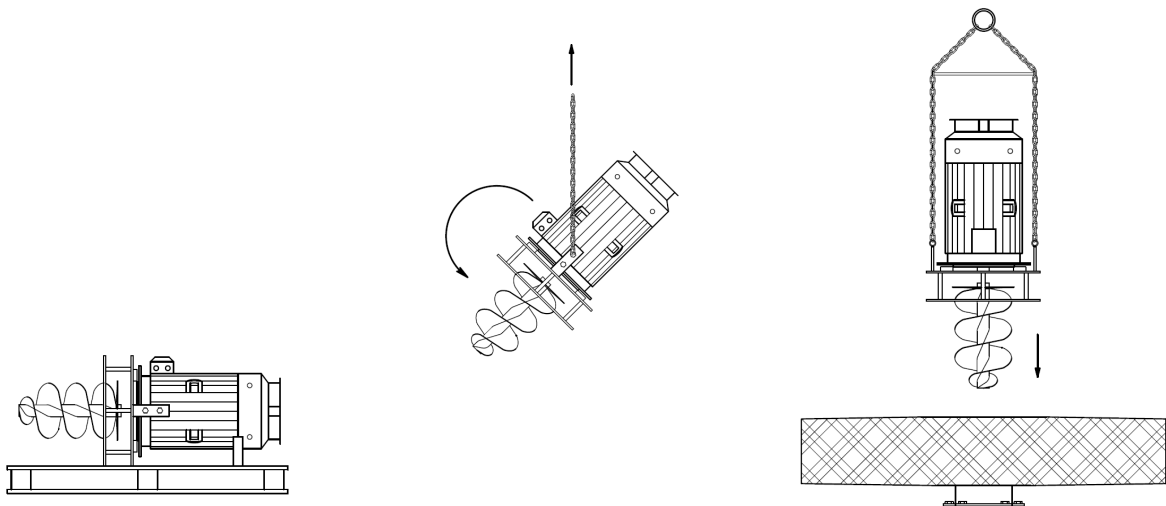

Drawing 5: Assembling power section and float

4.1.2. Assembly of the unit in case it is delivered in 2 parts

Check if the impeller turns freely in the volute.

Power section with float is to be positioned on top of the cone and fixed to it by means of the flange-flange coupling with nuts and bolts. **Always use self-locking nuts!**

A positioning stud on the flange of the cone / cross and a hole in the flange of the float ensures the correct positioning of the cone cross and float. It is strongly recommended not to start the aerator before the aerator is completely installed in accordance with the instructions described by ATB. Starting the aerator on dry land should not be done without making radical safety provisions. Should any abnormality occur, the aerator must be switched off immediately!

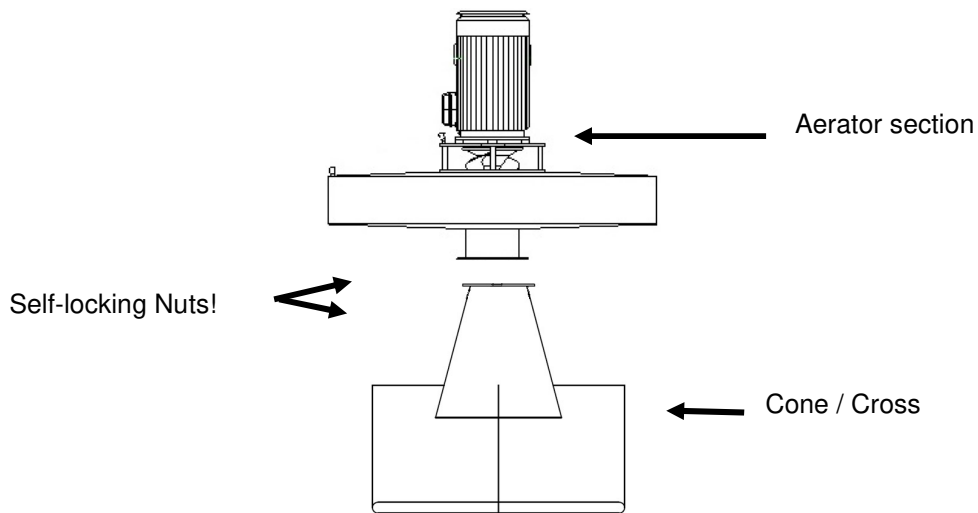

Drawing 6: Assembling the aerator

4.2. Overview of mooring systems

Depending on the water level variations, we distinguish the following mooring systems, ranked according to increasing water level variations:

- Mooring with cables, eventually combined with springs, for small water level variations
- Mooring with hinged arm, with or without lateral cables
- Mooring with sliding attachments, for large water level variations

When you are using a different kind of mooring system, due to a specific situation, this must always be done in dialogue with, and with the approval of ATB.

Any warranty claim for damage to the unit or others, due to a faulty designed mooring system, not approved by ATB, will be void.

4.2.1. Mooring with cables

There are usually three anchors, which are equally spread over the periphery of the float. Optionally (if ordered) the aerator can be supplied with 4 mooring cables.

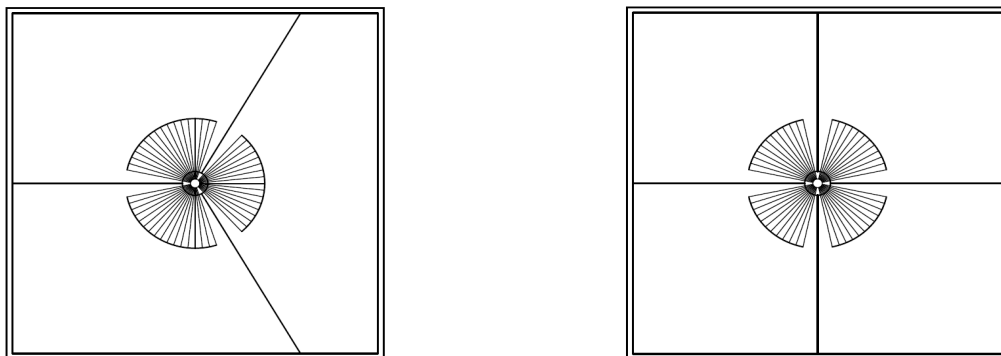

In case of limited water level variations, one can simply mount a mooring spring in series with the mooring cables. The decision to adopt this solution will however depend on the geometry of the basin and the position of the aerator in the basin.

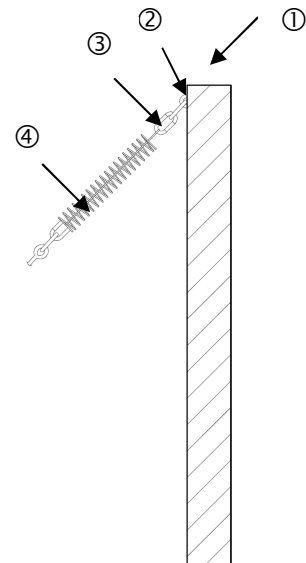
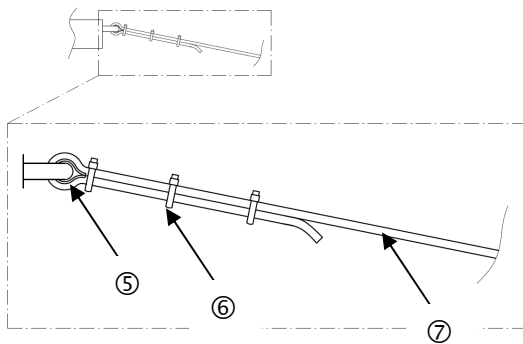

- ① Basin Wall
- ② Mooring Anchor
- ③ Quick Link
- ④ Retention Spring
- ⑤ Thimble
- ⑥ Rope Clips
- ⑦ Mooring cable

Drawing 7: Mooring cables, thimbles, clips, quick connectors and springs

If the water level-variation exceeds 1 meter, please contact ATB to agree on the suitable guiding system. ATB should always approve this guidance system.

Any warranty claim for damage to the unit or others, due to a faulty designed mooring system not approved by ATB, will be void.

4.2.2. Hinged arm

This mooring system is ideal in following cases:

- For limited water level variations, which however may be more than for the mooring system with cables and springs.
- In case of high above ground tanks, to limit the number of required access locations for maintenance.
- To simplify the mooring system and accessibility when a large number of aerators are used.

The hinged arm connects the aerator to the side of the basin and allows the unit to follow the water level variation.



If the water level variation would be such that the aerator would come too close to the wall and the aerator spray would consequently hit the basin wall under a certain minimum water level, one should stop the aerator from that level down.



It is of high importance that, during the movement caused by the varying water level, the arm never rests on the wall-side, as it can cause the arm to bend and break.

If, for whatever reason, the water level has to be lowered, the aerator has to be removed first.



When the hinged arm is connected to the assembled HSA, the aerator + arm assembly is not stable outside the basin!

The hinged arm mooring system consists of 2 or 3 parts, depending on the execution. There are several possible executions, but the system always consists of the following:

- wall fixation part
- arm, provided with hinge part at both ends, for hinged connection to the wall fixation part at one side, and to the aerator at the other side

a) Hinged arm, basic execution

This execution simply consists of a wall fixation and an arm.

If important flows are expected in the basin (f. ex. in oxidation ditch), extra mooring cables should be foreseen to reduce the sideward forces on the arm.

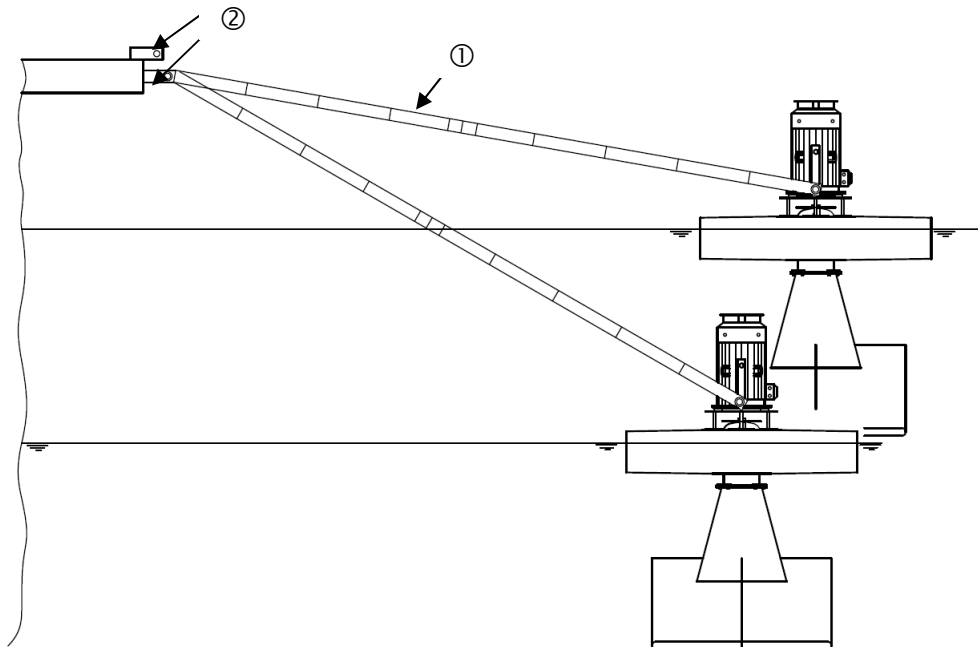

- ① Arm
- ② Wall fixation (installed on the side or on the top)

Drawing 8a: Hinged arm, basic execution

b) Hinged arm with 2 degrees of freedom

In some cases, the wall fixation has two different hinge axes, allowing vertical and horizontal movement of the arm. In this execution, the arm will always be equipped with mooring cables to hold it in the operational position, while reducing the forces on arm and hinge.

The cables will also allow pulling the aerator to the side for maintenance.

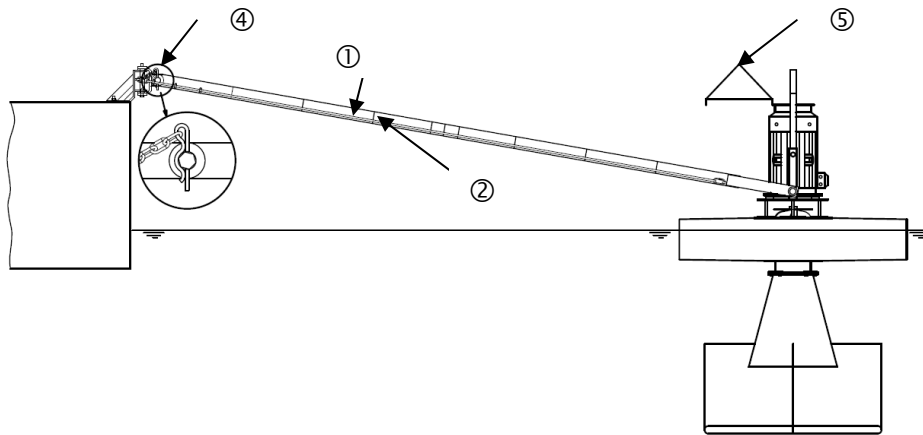

- ① Mooring Arm
- ② Mooring cable
- ④ Wall fixation installed on the top of the wall
- ⑤ Lifting bracket (optional)

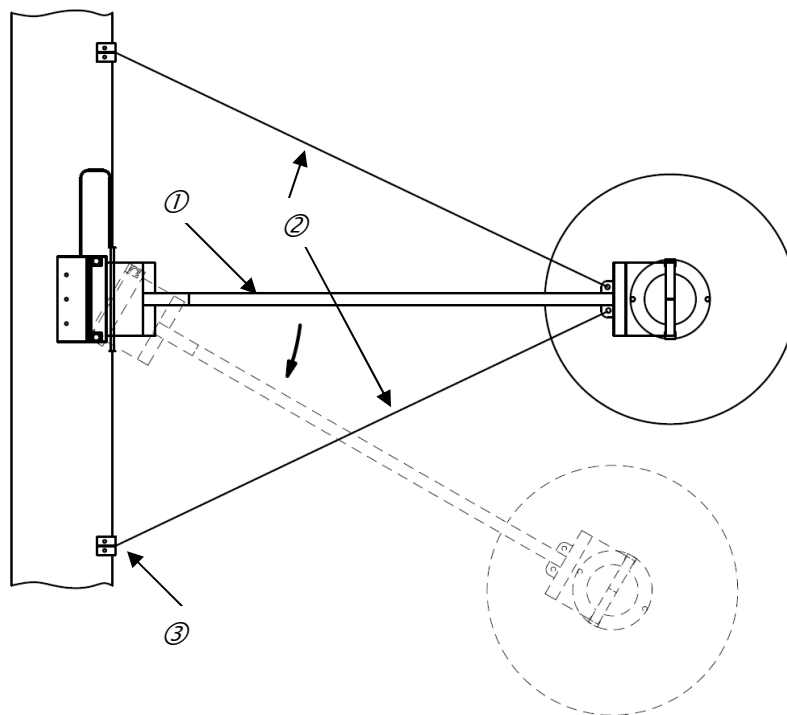

- ① Mooring arm
- ② Mooring cables
- ③ Mooring anchors

Drawing 8b: Hinged arm with 2 degrees of freedom

4.2.3. Vertical guiding system

When the water level variation is such that the cable length variation cannot be covered by one compression spring, or that the angle variation between the cable/hinged arm and the water line is too important, the mooring with a vertical sliding attachment should be used.

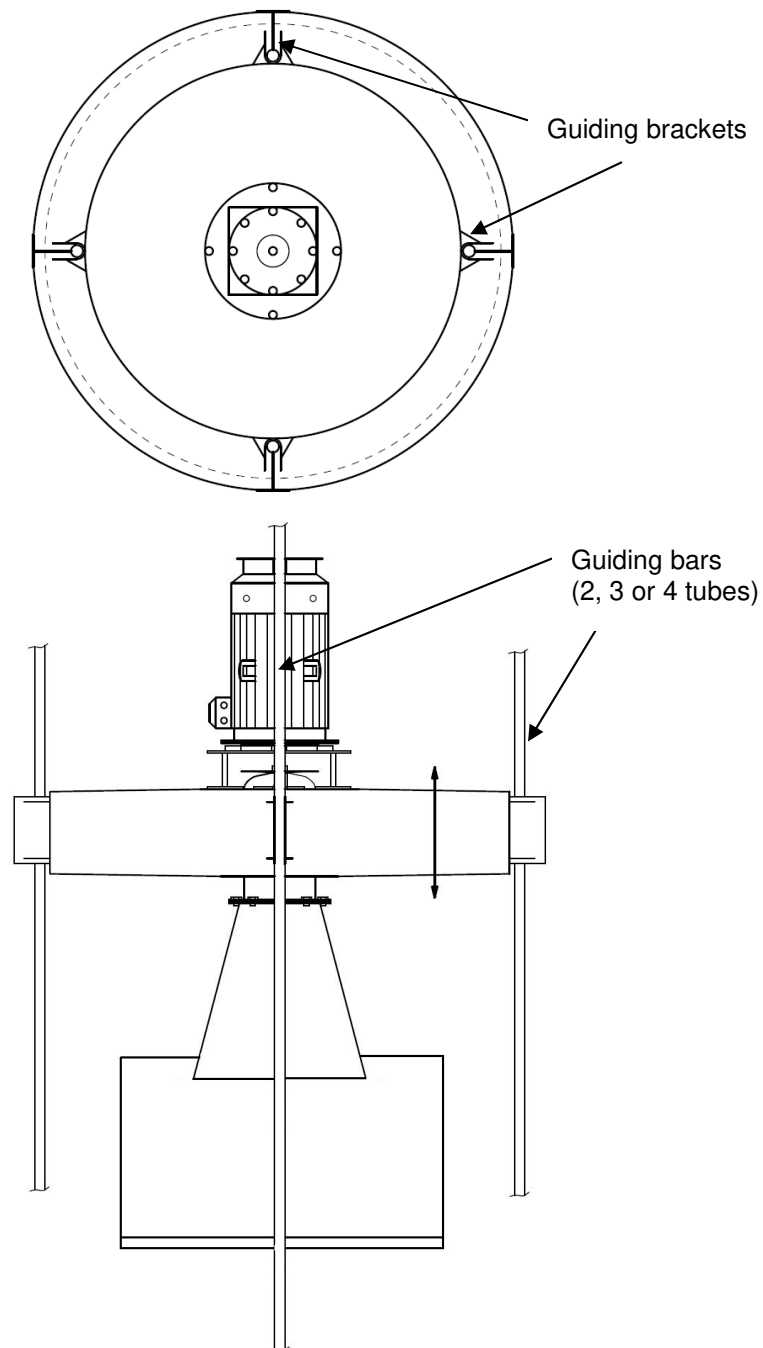

Drawing 9: Vertical guiding system

4.3. Installation



As a safety precaution, the installation of the unit must always be performed by at least two persons.

Once the unit is completely assembled, the entire unit can be lifted by the lifting lugs welded to the motor support, and positioned in the tank. Be sure that the cables or chains are not twisted. Also make sure that the lifting chains can not damage the aerator.



IMPORTANT NOTE:

The assembled surface aerator can be placed on the bottom of the basin during installation. It must be secured against tipping with the help of the guiding system. If this is not possible, the aerator must be secured by a support structure made by the customer.

Permanent set up of the assembled aerator on the bottom of the basin or permanent storage in this condition is not permitted. If, despite this, the aerator is to be stored or set up in the assembled state for a longer period of time, the weight of the float/ motor must be relieved from the intake cone/cone cross by means of a suitable support structure provided by the customer.

The following major positioning rules need to be respected:

- Before mounting the aerator in the basin, you are advised to check with ATB to avoid incorrect positioning.
- The aerator has to be placed in such a way that the openings in the spray are perpendicular to the side (wall) of the basin.
- The power cable should be directed in one of the openings of the spray. Incorrect location of the power cables can cause splashing on the motor.
- Never place any construction directly into the spray of the aerator to avoid splashes towards the motor.



As a safety precaution and to prevent the unit from tipping, it is prohibited to stand on the HSA float at any time.



In all mooring cases, make sure to limit the over length of cable and to fix the electrical cable in such a way that it can not be aspirated by the HSA helical impeller in any position between the minimum and maximum water level!

4.3.1. Mounting sequence for installation with mooring cables

If the electrical cable and mooring cables are supplied by ATB, they will normally already be connected to the HSA. If this is not the case, the mooring cables have to be attached to the mooring anchors at float side, and the electrical cable has to be connected inside the junction box of the motor, prior to the installation in the basin.

Place the aerator in the water near shore, wall or platform and loosen the lifting cable or chains. Using the mooring cables, the unit can be pulled into its final position.

The mooring cables have to be attached to the mooring anchors at the side of the basin.

Installation/Operating Instructions ATB - HSA

Locate the mooring points so the angle enclosed by any 2 subsequent cables is equal (120° in case of 3 cables; 90° in case of 4 cables).

Locate the mooring points (at basin side) in such a way that the angle enclosed by any 2 subsequent cables is equal (120° in case of 3 cables; 90° in case of 4 cables).

In case of limited water level variations, one or more compression springs might be requested in between the cable ends and the mooring anchors at basin side. Please check the tension in the cables regularly.

If the water level-variation is such that 1 standard spring is not enough to compensate the variation of distance between the mooring anchor at basin side and float, please contact ATB to agree on the suitable guiding system. This guiding system should always be approved by ATB.

In case no variation of the water level occurs and no springs are used, the angle between the mooring cable and the water surface should not exceed 15°. (Ratio between the height of mooring location above the water surface and the cable length should be $\pm 1/4$).

Following mooring means are available for basin side fixation:

- Mooring Anchor, for Concrete Walls or Steel Tanks

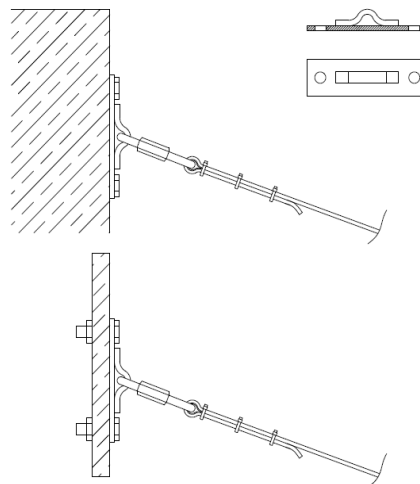

Drawing 10: Mooring Anchor for concrete wall or steel tank

- Mooring post, for earthen basins

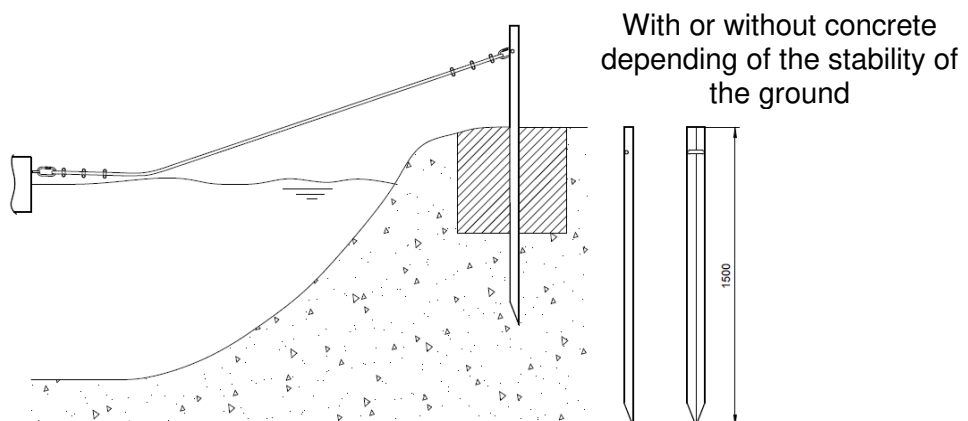

Drawing 11: Mooring post for earthen basins

Installation/Operating Instructions ATB - HSA

The strength of each one of these mooring systems and their fixation should overpass the strength of the mooring cable provided. Selection and provision of these mooring methods should be submitted to ATB for approval.

It is advisable to follow the instructions in **enclosure II** for a correct assembly of the mooring cables.

The mooring cables are used to keep the surface aerator in the right place in the basin or in the lagoon.

The device must "all the time" float independently on the water surface.

Mooring cables must be detached if the water level would drop below the minimum allowable level, e.g. when the tank should be emptied or during a particular maintenance work.

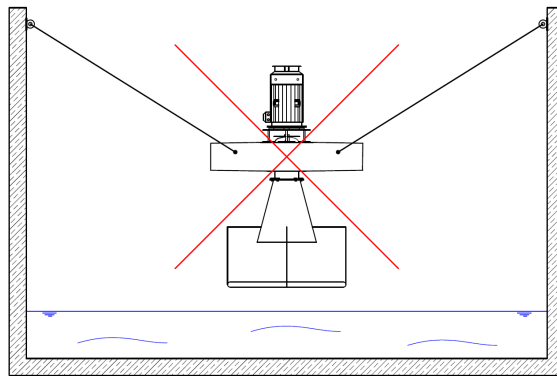

Mooring cables can in no way serve to raise the device above the water, or to keep the device above the water level.

ATB cannot be held liable for accidents caused by non-compliance with these instructions.

Once the HSA is in its final position, the mooring cables can be tensioned. A sag of $\pm 2\text{cm}$ per meter mooring cable is recommended. Excessive tightening may damage the cables in the long run. Under no circumstances mechanical tools are to be used to facilitate additional tightening.

If the HSA is in the correct position, the electrical cable can be connected to the junction box on the side of the basin. Make sure to attach the electric cable to an anchor before it enters the junction box, to avoid that the electric cable pulls at the cable gland entering the junction box.

We refer to section 4.4. for further electrical connection details.

4.3.2. Mounting sequence for hinged arm system

a) Basic hinged arm or hinged arm with 2 degrees of freedom

Once the aerator unit is assembled according to the description under 4.1. "Assembly of aerator unit", the mooring arm needs to be mounted to the aerator (with or without the mooring cables, depending on the execution).

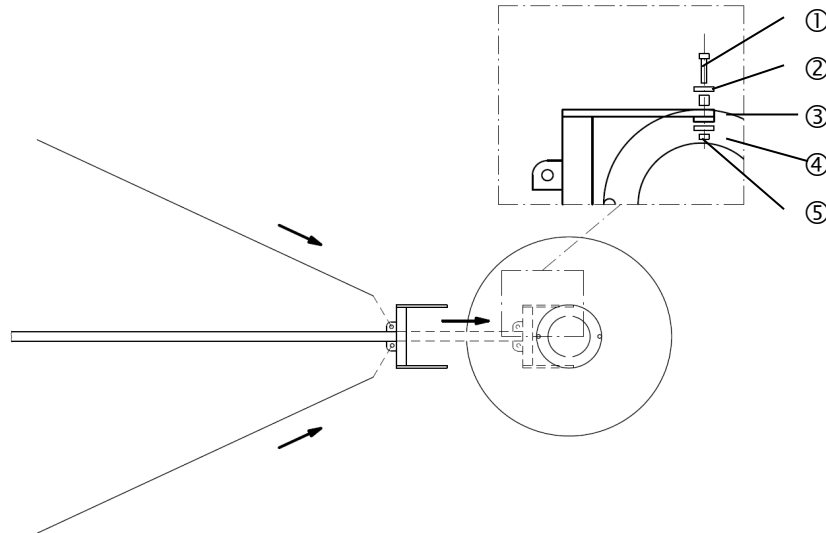

Connection detail:

- ① Bolt
- ② Washer
- ③ Bush
- ④ Washer
- ⑤ Nut with nylon insert (optional: nut + spring washer with split pin)

Drawing 12a: Mounting of the hinged arm to the aerator

Next, attach the power cable along the hinged arm, whereby care must be taken to leave enough spare cable length between the motor junction box and the beginning of the arm at aerator side (See drawing 19b.: "Position of the power cable with hinged arm").

Now you may lift the aerator and its hinged arm, and next lower it in the basin.



For vertical lifting of the unit, and to avoid handling damage, a double chain should be used (see drawing).

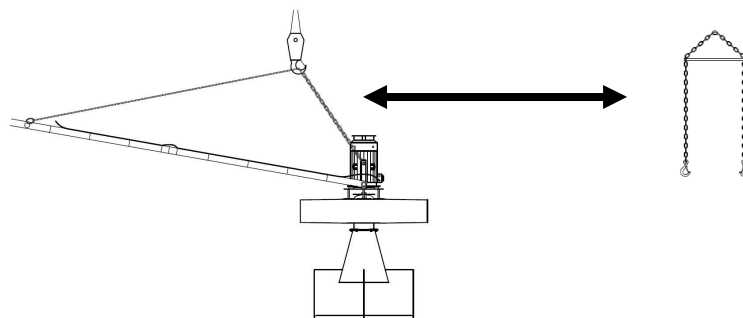

Drawing 12b: Lifting of the hinged arm

Once the aerator is floating, you can connect the other end of the arm to the wall fixation part, which should have been mounted previously. If used, attach the mooring cables to the wall by means of the mooring brackets, which should be located somewhere in the prolongement of the hinge axis line.

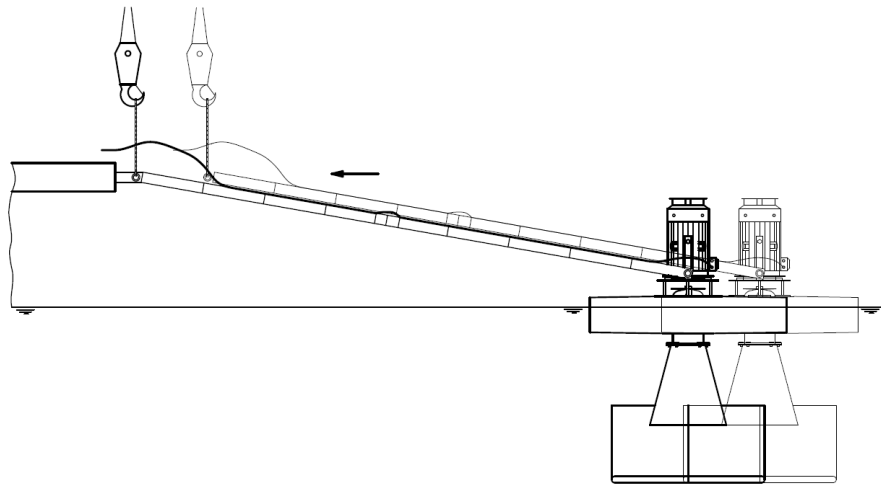

Drawing 12c.: Mounting of the hinged arm to the wall fixation

If the HSA is in the correct position, the electrical cable can be connected to the junction box on the side of the basin. Make sure to attach the electric cable to an anchor before it enters the junction box, to avoid that the electric cable pulls at the cable gland entering the junction box. We refer to section 4.4. for further electrical connection details.

4.3.3. Mounting sequence for the vertical guiding system

If the electrical cable is supplied by ATB, it will normally already be connected to the HSA. If this is not the case, the electrical cable has to be connected inside the junction box of the motor, prior to the installation in the basin.

If ATB doesn't supply the guiding posts, it is imperative that the customer either produces these posts according to the indications he receives from ATB, or sends information about the exact location of existing posts, as well as the diameter of those posts, in order to foresee the appropriate sliding arrangement.

The guiding posts need to be fixed to the floor of the basin and the basin side, prior to the installation of the HSA into the basin. For the installation of these posts, assuming these are part of the ATB delivery, a separate installation drawing will be sent, indicating the exact location of these posts.



When installing / fixing the guiding tubes, it is essential to ensure that the tubes are vertical and parallel to each other (regardless of the position of the tank bottom), so that the guiding tubes have the same distance to each other at every height, so that the unit can move unhindered up and down between the guiding tubes.

Before commissioning, check that the unit can slide between the tubes over the entire height without any problem.

Installation/Operating Instructions ATB - HSA

On request, ATB can supply a spacer which is plugged into the upper side of the guiding tubes, whereby on the one hand the distance can be controlled and on the other hand additional stability of the guiding system can be achieved. This is particularly recommended for very long guiding tubes.

With a crane, lower the HSA in the middle of the guiding posts while making sure that the guiding brackets slide over the guiding posts.

This installation can also be done in an empty basin. It might be difficult to position and slide the guiding brackets over the guiding posts. We therefore advise you to attach 2 ropes to the HSA which will allow 2 persons to slightly move/rotate the unit when it is hanging in the crane at a few meters above the ground.

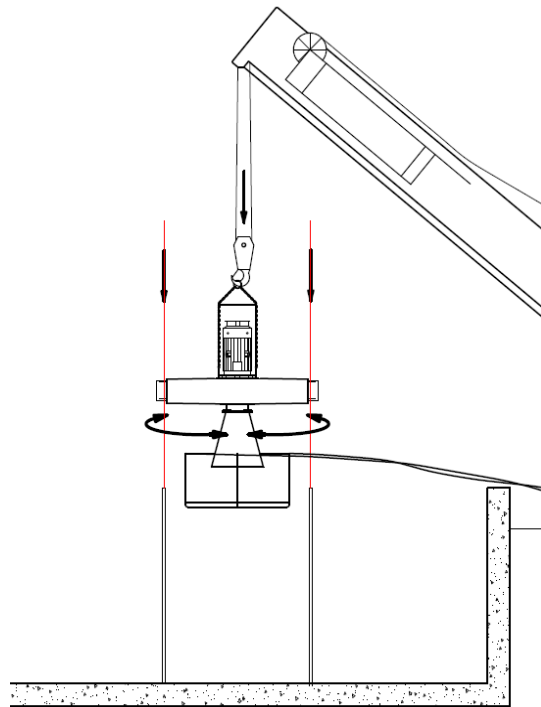

Drawing 13: Installation of the HSA with Vertical Guiding System



As a safety precaution, no person shall walk under the aerator when it is lifted by the crane.

If the basin is filled up before the HSA is placed between the guiding posts, a boat can be used to guide the HSA guiding brackets over the guiding posts.



Always wear safety jackets when working in or around a basin that is filled with water!

If the HSA is in the correct position, the electrical cable can be connected to the junction box on the side of the basin. Make sure to attach the electric cable to an anchor before it enters the junction box, to avoid that the electric cable pulls at the cable gland entering the junction box. We refer to section 4.4. for further electrical connection details.

4.4. Electrical cable and wiring instructions

4.4.1. General wiring instructions

If the power cable is included in the order, it has already been connected in the motor junction box at our workshop.

The control panel on the basin wall in which the electrical cable will be connected, has to be designed to conform to the European standard EN 60204 concerning electrical equipment of machinery.

In case the connection was not performed, both connections (in motor junction box and panel at basin side) should be made on site by a skilled electrician; make sure you follow all the steps mentioned below:

1. Take note of all data mentioned on the motor nameplate, prior to the assembly of the unit.
2. Check the power supply voltage and check if the correct connection (star, delta) was made. You can find the connection scheme in the junction box of the motor.
3. The cable section must be such that the line loss between the electric panel and the aerator is limited to $\pm 5\%$ of the nominal voltage. Too low voltage can reduce the motor life. When starting the aerator, the voltage at the terminals should not deviate more than 15 % from the nominal voltage, taken the starting current into account.
4. A good quality copper 4 conductor stranded flexible cable, rated for wet duty service, should be used (H07RNF, CTFBN, CTMBN, etc.). For application with frequency drive, Protoflex EMV-FC 2YSLCY-J type of cable should be used. The conductors-section should be chosen in relation to the amperage draw and the length of the cable.
5. An IP68 compression fitting must be used at the wire entrance of the motor junction box to enable a watertight connection. A shoddy connection or tightening could cause damage to the motor later on. In case of frequency drive, a special gland should be used, that makes contact with the cable shield.
6. All conductors must be securely tightened to the connectors in the motor junction box. If no connector is provided, bolt and nut connect the motor- and cable conductors. Rubber insulated tape shall be used to wrap each set of conductors to reach a thickness of insulation of minimum 5 mm.
7. Make sure that the cable cannot be sucked into the aerator unit, caused by a superfluous length of the cable. Anyway, the cable length should be a little oversized to be sure that the unit axis remains vertical (distance between HSA and basin edge x 1,2).
8. The strain relief is mounted on the flange support and gives the electric cable the right direction to the basin edge. At basin edge, the electric cable should also be clamped to avoid tension on the connection box at basin side.



We recommend you to check the tension of the electrical connection in the junction box and in the connecting box at least once a year.

Recommended tightening torque of the electrical connection:

- M5: 4 Nm
- M6: 7 Nm
- M10: 14 Nm

4.4.2. Position of the electrical cable

The power cable should never hang in the aerator spray, but pass through the V-openings in the spray.

The electrical cable may never be mechanically loaded and needs to be correctly attached in the strain reliefs of the aerator.

The fixing of the electrical cable depends on the distance between the aerator and the wall of the basin.

- 1) With a short distance (up to 15m) the cable can be safely attached to the edge of the basin with a quick coupler and a tightener.

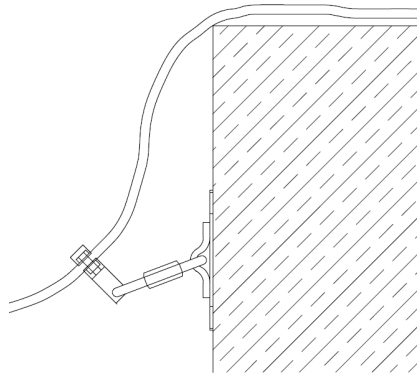

Drawing 14: Fixation of the electrical cable with quick coupler and tightener

Optionally the electrical cable can be fixed by a pulling cable that can be ordered.

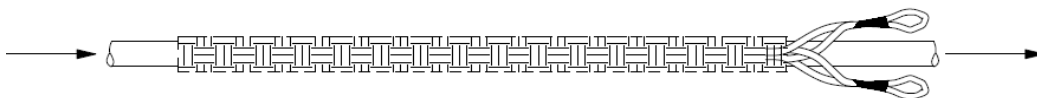

Drawing 15: Mounting of the electrical cable with pulling

The pulling cable is mounted to the wall of the basin with a quick coupler and a mooring hook. The pulling cable may have 1 or 2 pulling hooks.

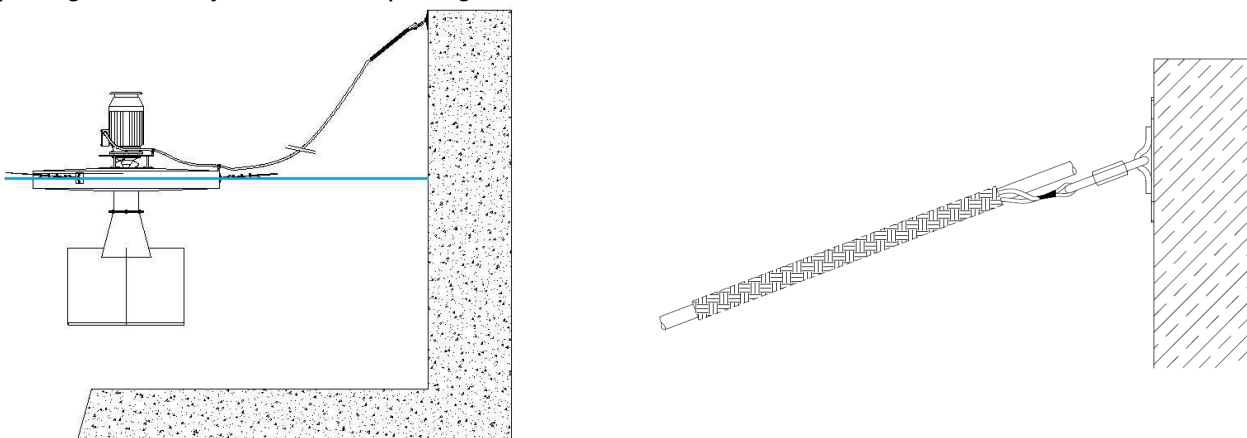

Drawing 16: Fixation of the electrical cable with pulling cable

Installation/Operating Instructions ATB - HSA

- 2) When the distance is more than 15m the same solutions are possible, or the cable can be attached to one of the mooring cables by using pulling strips. The electrical cable is fixed each meter to the mooring cable with the pulling strips. It is important, to avoid a mechanical load on the electrical cable, that between each pair of pulling strips the length of the electrical cable is bigger than the length of the mooring cable. It is also possible to install an extra cable between the aerator and the wall of the basin. The electrical cable can be fixed to this extra cable with the pulling strips.

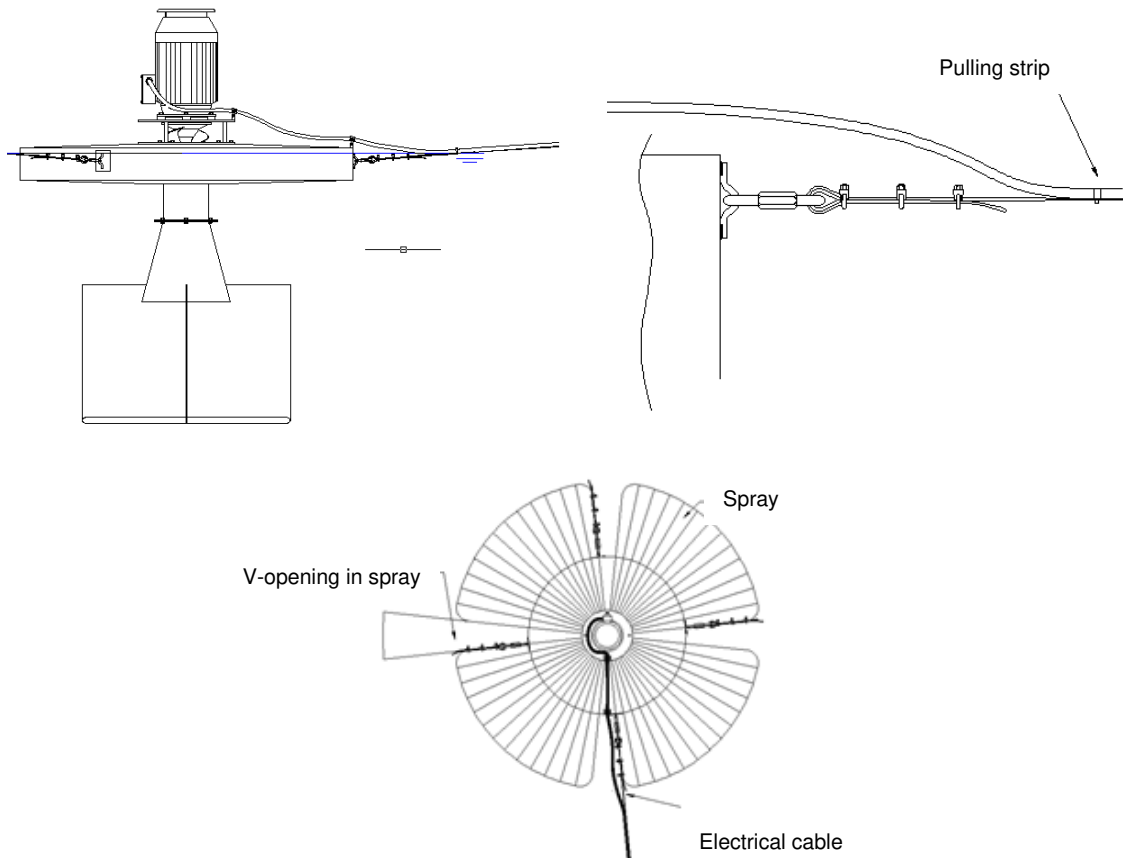

Drawing 17: Mounting of the electrical cable with pulling strips

- 3) When the fixation of the electrical cable to the mooring or extra cable isn't possible, the cable can be placed on the bottom of the basin. Or it's possible to use floaters that can be ordered. When the cable is placed on the bottom of the tank he may not lay underneath an aerator to prevent suction of the cable into the device.

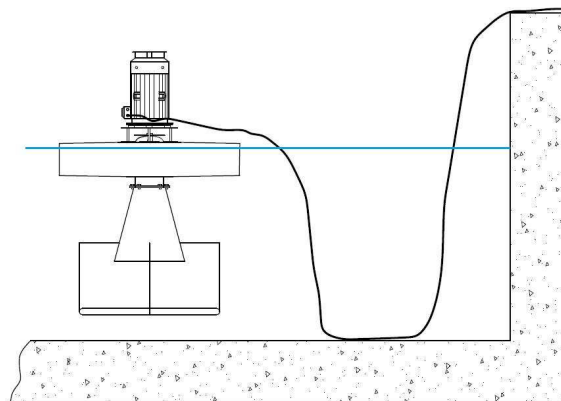

Drawing 18a: Electrical cable on the bottom of the basin

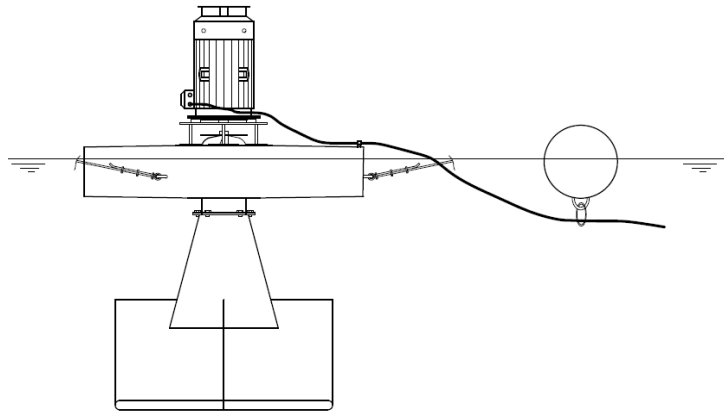

Drawing 18b: Mounting of the electrical cable by using floaters

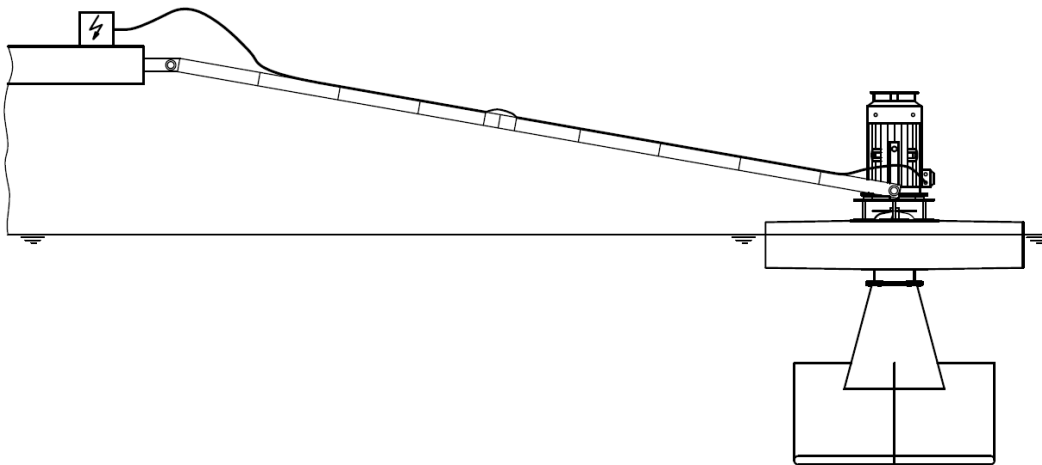

Drawing 19a: Position of the power cable with hinged arm

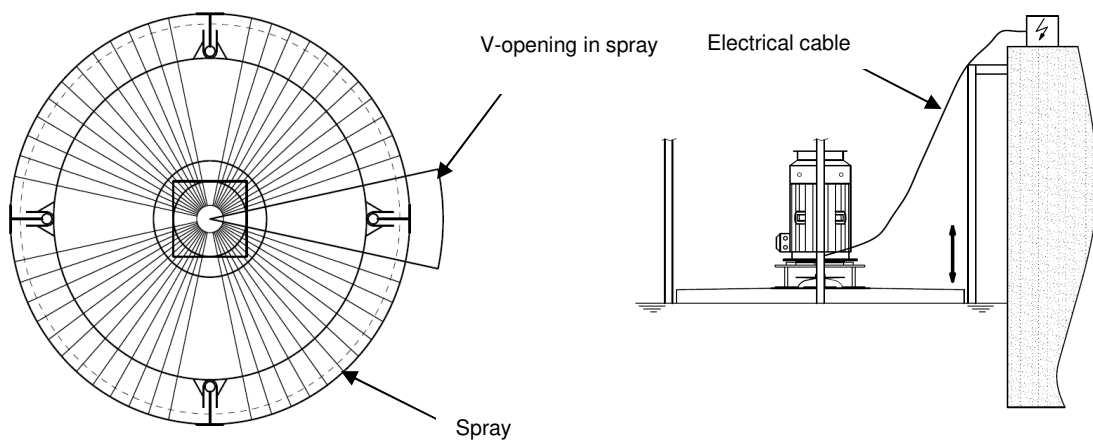

Drawing 19b: Position of the power cable with guiding system

4.4.3. Electrical connection diagrams

DIRECT ON LINE CONNECTION:



VERY IMPORTANT NOTE FOR DOL START OF MOTORS OF 4 KW AND MORE:

It is mandatory to start the motor via a **soft starter** in order not to overload the power grid and to minimize the mechanical stress (torque) on the motor in the starting phase. In the event of non-compliance with this restriction, please contact ATB to discuss this topic otherwise warranty will be void.

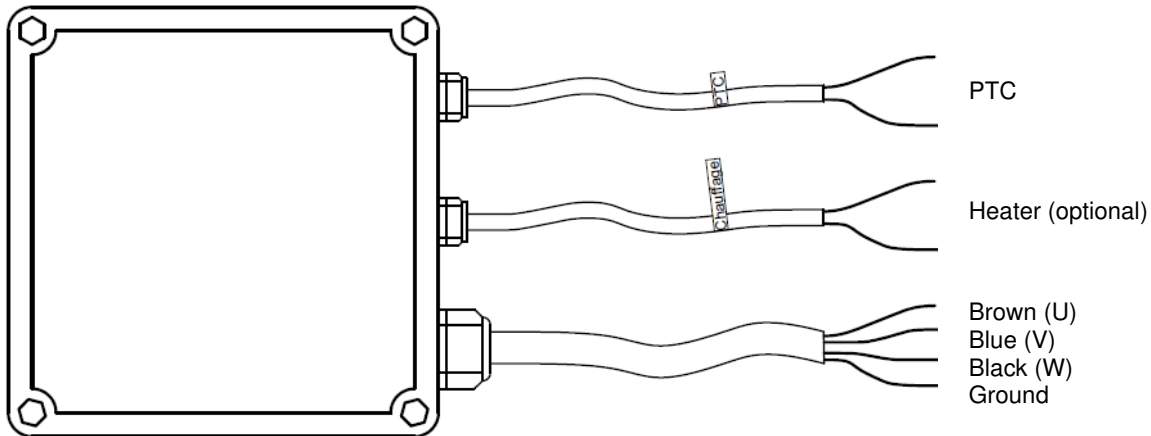

For this connection, put power supply on U (Brown), V (Blue), and W (Black) and connect the PTC. Heater is optional.

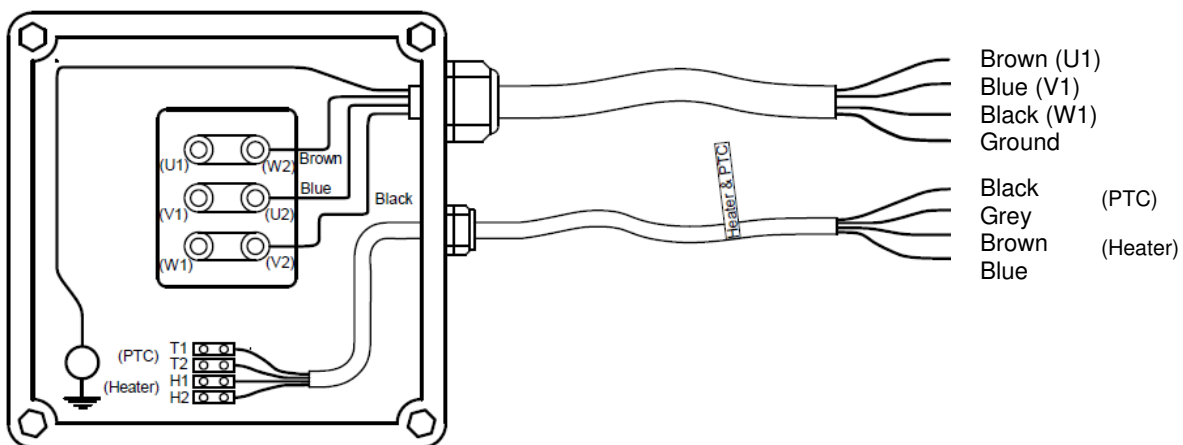

For this connection, put power supply on U1 (Brown), V1 (Blue), and W1 (Black). Connect the PTC on T1 and T2 (Black and Grey). Connect the optional heater on H1 and H2 (Brown and Blue).

STAR – DELTA CONNECTION:

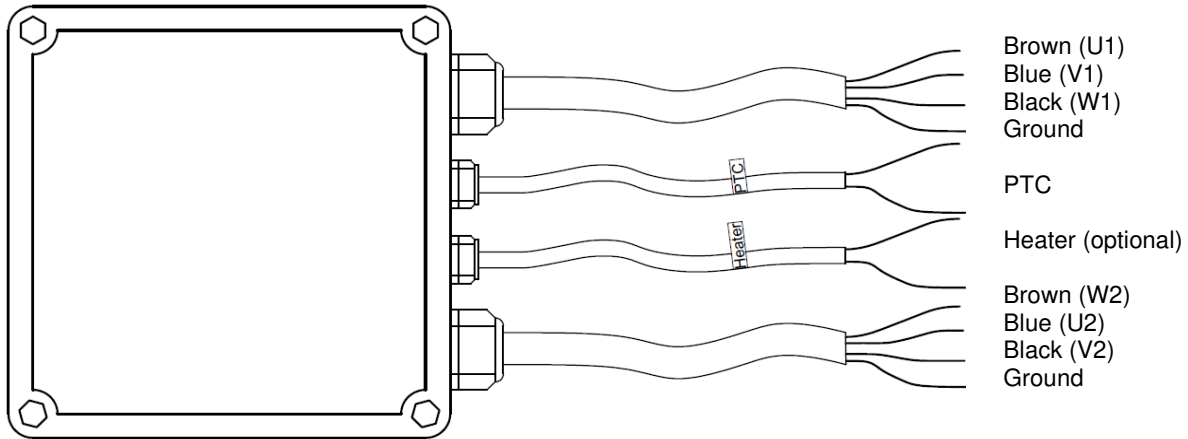

For STAR connection: Link U2, V2 & W2 together and connect power supply cable to U1, V1 & W1.

For DELTA connection: Link U1 (Brown) & W2 (Brown)
 Link V1 (Blue) & U2 (Blue)
 Link W1 (Black) & V2 (Black)

and connect the 3 phases of the electric power supply to the 3 connected leads.

Connect the PTC.

Heater is optional.

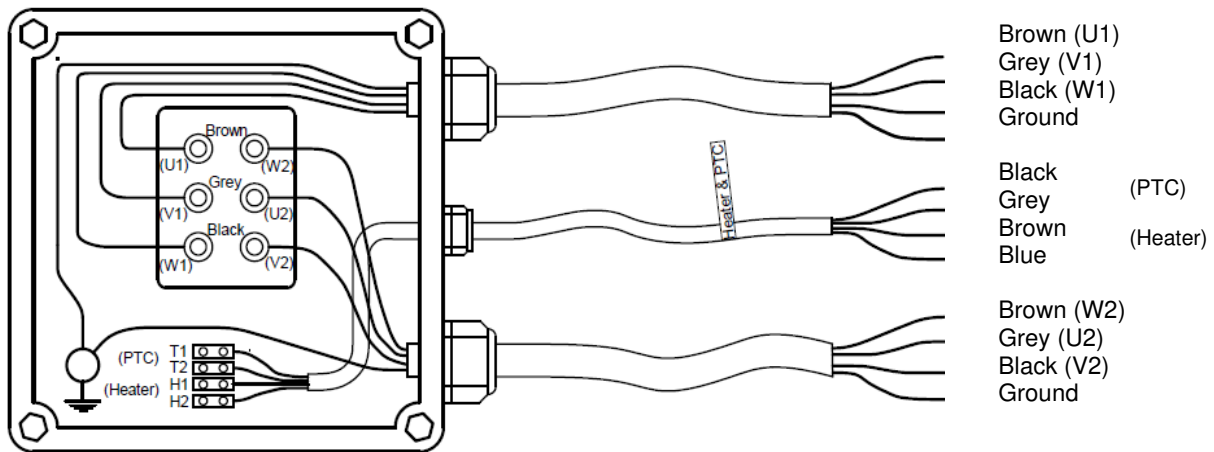

For STAR connection: Link U2, V2 & W2 together and connect power supply cable to U1, V1 & W1.

For DELTA connection: Link U1 (Brown) & W2 (Brown)
 Link V1 (Blue) & U2 (Blue)
 Link W1 (Black) & V2 (Black)

and connect the 3 phases of the electric power supply to the 3 connected leads.

Connect the PTC on T1 and T2 (Black and Grey). Connect the optional heater on H1 and H2 (Brown and Blue).

CONNECTION WITH FREQUENCY DRIVE:

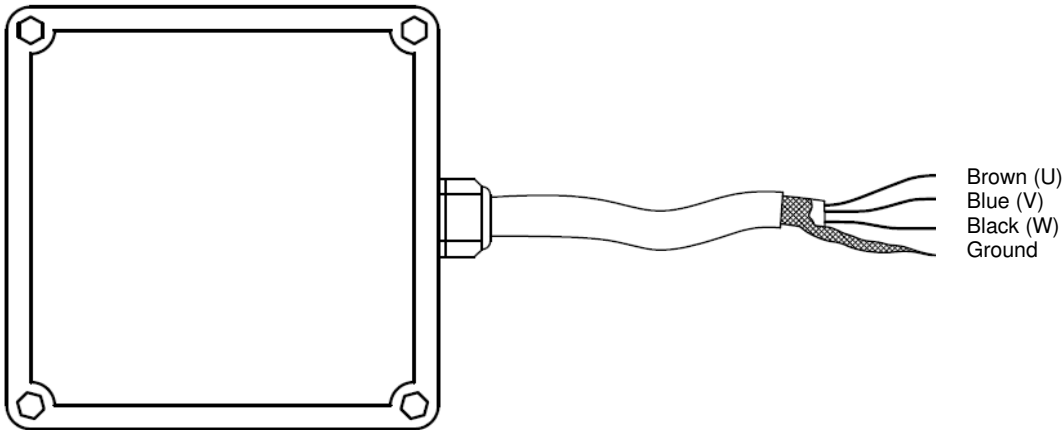

For this connection, connect the frequency drive to U (Brown), V (Blue), and W (Black) and connect the PTC. The heater is optional.

Electrical connection

As the type of connection will depend on the type of power supply, and startup procedure, please verify data on motor nameplate and see appropriate chapter (5.4.2.) for the connection.

Our standard electrical cables are suitable for frequency drive.

ALLOWED CONNECTIONS / STARTING PROCEDURES FOR TEFC MOTORS

Power supply	Allowed voltage supply to motor (see motor nameplate)	Authorised start procedure	Required power leads
240V – 3P	240 – 400V	STAR/DELTA	6
		DELTA DOL	3
400V – 3P	240 – 400V	STAR DOL	3
400V – 3P	400 – 690V	STAR/DELTA	6
		DELTA DOL	3
690V – 3P	400 – 690V	STAR DOL	3



VERY IMPORTANT NOTE FOR DOL START OF MOTORS OF 4 KW AND MORE:

It is mandatory to start the motor via a **soft starter** in order not to overload the power grid and to minimize the mechanical stress (torque) on the motor in the starting phase. In the event of non-compliance with this restriction, please contact ATB to discuss this topic otherwise warranty will be void.

Installation/Operating Instructions ATB - HSA

- If authorised, STAR/DELTA start procedure

→ During the first 2 seconds: STAR connection

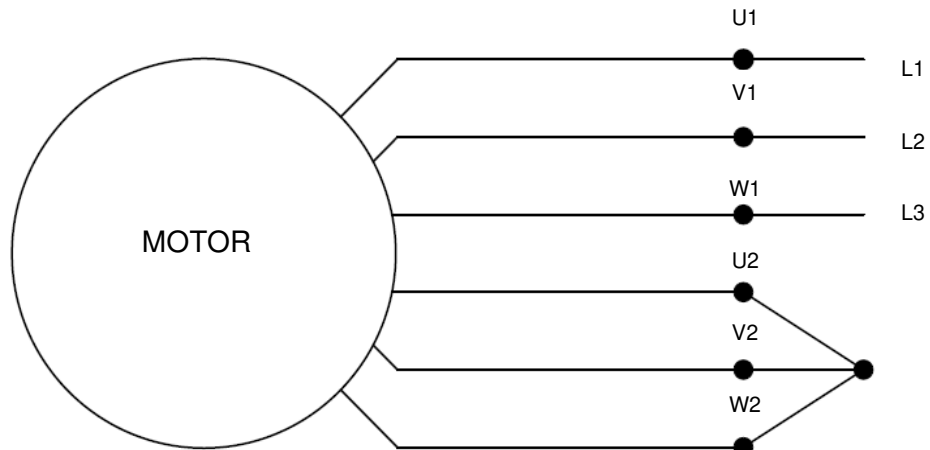

Fig. A

→ After 2 seconds: DELTA connection

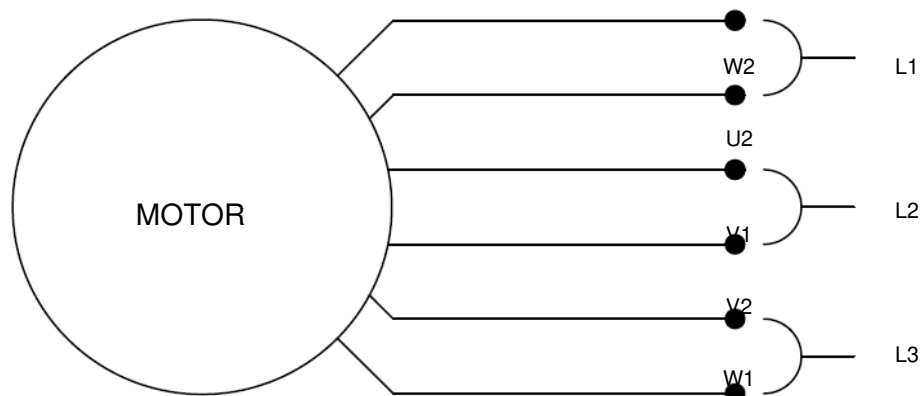

Fig. B

- If authorised, DOL STAR start-procedure

See fig. A

- If authorised, DOL DELTA start-procedure

See fig. B



IMPORTANT NOTE ON THE OPERATING MODE OF THE MOTOR

The high starting current of asynchronous machines causes a temperature rise in the motor at startup. There is a risk of thermal damage to the motor winding due to the short time intervals between starts.

If operating mode S1 (continuous operation) is indicated on the type plate, the following starting procedures are permitted:

- Two successive starts: first start from cold condition, i. e., the motor windings are at room temperature and the second start immediately after the motor stops;
- One start from hot condition, i. e., the motor windings are at rated temperature.

In all cases, the PTC (see below) must be connected.

In the case of a star-delta start or via a soft starter or frequency converter, the starting current is lower and the starting frequency is different. In the specific case, we must be informed about the frequency of the switch-on and switch-off processes and other operationally relevant data (outside temperature, altitude above sea level, humidity, other special operating conditions) so that we can have the permissible switch-on frequency calculated by the motor manufacturer.

Temperature detector:

PTC's are characterized by the fact that their resistance varies little at raising temperatures until the reference-temperature has been reached (150 °C for the motors we use). Above this critical temperature, the resistance raises very fast.

Motors are standard equipped with such PTC thermistors (TYPE PYRE 155 A1).

These PTC's must be connected to a separate control relay which interrupts the power supply to the motor when the resistance of the PTC gets over the critical point.



CAUTION:

The existing PTC is connected by ATB on the motor side. The connection of the PTC is absolutely necessary on site. If no connection is made, frequent cycles can result in engine damage. In this case a warranty is excluded. In addition, we expressly refer to the O&M Engine Manual in enclosure.

Heating:

In case the aerator(s) are applied in a humid environment, with many stops, and/or in case of foaming, we recommend, as a first step towards a solution, to order a motor with a heater.

The heating element's power varies between 10 and 150 Watt.

Alternatively, when the motors don't operate, one can also connect a small tension over one phase of the windings.

Very often an alternating voltage is used of approximately 10 % of the nominal tension.

Always contact ATB before applying this solution.



The space heaters should never be energized when the motor is in operation!

4.5. Start up



Before starting up the unit, make sure that no foreign objects (wood, plastic, etc...) are located in the basins. These objects can be sucked into the unit and could damage it. ATB will not accept liability for such damage. These objects should normally not find their way into the basin, as they should be stopped by a filter or a screen, placed upstream of the supply towards the basin.



No one shall be sitting in a boat near the HSA as long as the safety switch has not been switched OFF and locked in this position.



IMPORTANT NOTE:

Please check all screwed connections (Motor, Flange/Power section, Cone-Cross) on right tightness! Use a dynamometric key. Tightening torque is shown in table 1 (see at the beginning of this chapter).

After all the above steps have been carried out correctly, you can start the unit while observing its spray.

If a full spray is observed all around, this means the motor is running correctly.

If almost no spray is observed at aerator startup, but only splashing and a knocking noise is noted, this means the motor is running in reverse. Reverse two line connections of the power cable after you have first disconnected the main switch. If a frequency drive is used, reverse 2 phases of the cable coming from the frequency drive.



IMPORTANT!!!

The HSA should never run in reverse for longer than a few seconds! Generally, running in reverse when the unit is installed in the water should be avoided at all times. If it accidentally happens, the unit should be stopped immediately.

If the motor is damaged due to running in reverse, **WARRANTY WILL BE VOID!!!**

Next start the aerator again and check the normal pattern of the spray.

Check the exact consumed power and the following data: voltage, current, power factor. There are instruments¹ that can measure these data simultaneously and print it out. Such a device is advised to attain exact measurement of the power.

Significant underloading, any overloading, or remarks concerning the spray, noise, instabilities... should be mentioned and discussed immediately with ATB. In this case the unit should be stopped immediately.

If everything is normal, let the unit run for at least 30 minutes and then analyze the power consumption again.

In some cases it is possible that, at start up of the aerator, the motor is overloaded due to high sludge concentration in the intake area under the aerator.

Normally, the problem will be resolved after approximately one hour, since the sludge will be mixed with the liquid fraction.



VERY IMPORTANT:

A foam layer may never cover the motor, neither partly or completely. Defects resulting from such situations will not be covered by the warranty.

If foam is unavoidable, please contact ATB, to discuss the appropriate solution.

Special execution with heater inside the motor

The motor of a standard unit may never be partially or completely covered by a foam layer. In case foam is expected to occur accidentally, an anti-condensation heater is required inside the motor (although it isn't a fail safe solution).

In this case, it is very important to always switch on the heating elements when the motor is not running. If the motor cools down, the air inside the motor will reduce in volume, which will create an underpressure inside the motor. This underpressure will suck moisture inside the motor. Several stops without the heater switched on will cause water damage inside the motor, if the motor is covered with foam.



Always inform ATB if the foam layer reaches the motor!

In case a foam layer is expected constantly or regularly, another solution should be discussed with ATB.

5. Maintenance



During maintenance or repair, all safety switches (=breakers) have to be switched OFF and locked in this position.

- Occasionally the unit's operation should be checked visually. Any accumulation of debris behind the legs of the flange support must be cleared at once.
- When the ambient temperature drops below 0°C, check at least once a day there is no excessive accumulation of ice on the aerator as this could jeopardize the stability of the unit and eventually cause the aerator to tip over.
- Accumulation of enclosed motor O&M manual fins of the motor and on the air inlet holes in the motor cap should be avoided, as this can hinder the cooling of the motor, with serious consequences.
- Depending on motor size and manufacturer it is possible that bearings have to be greased. Please see for this topic (need and frequency) the motor O&M manual in enclosure.
- Use the correct fitting for the grease nipple. The grease nipples are located either directly on the motor (in most cases) or on an extension mounted onto the motor.

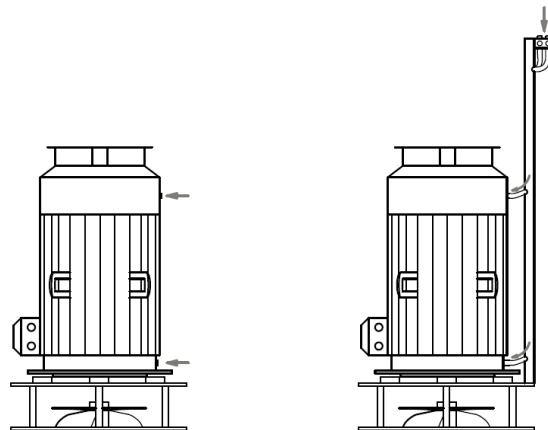

Standard greasing

Extended greasing

The old grease will exit the motor either near the shaft (not visible) or at the opposite side of the fitting, through the relief opening (diametrically opposed to the grease nipple). During greasing, the amount of grease, indicated by the motor manufacturer, should be pumped into the bearings.



Both undergreasing and overgreasing will destroy the bearings.

We refer to the enclosed motor O&M manual for quantities of grease and recommended grease types.

Installation/Operating Instructions ATB - HSA

- Electrical connections should be tightened yearly. Make sure the cover of the motor terminal box fits tightly and is closed correctly.
- Finally check periodically the mooring cables to be certain they are still securely fixed and not too loose. If necessary, re-tighten them.
- Please check all screwed connections (Motor, Flange/Power section, Cone-Cross) on right tightness! Use a dynamometric key. Tightening torque is shown in table 1 (chapter 4).

Enclosed you will find a maintenance sheet which can be used for each unit.



Extraordinary maintenance and repairs must be carried out by ATB or by ATB authorized workshops.



If any abnormality is observed, call ATB.

6. Storage

6.1. Temporary storage (= 1 up to 4 weeks)

If the unit is stored outside the water, the float, HELICAL IMPELLER and motor assembly, have to be disassembled from the stabilisation cross, to avoid tipping over.

In case of outdoor storage, the motor must be covered with plastic without sealing it, to allow air circulation.

Take special care that in no case the helical impeller can get damaged. Even a small deformation of a few millimetres can cause vibrations and electrical overload of the unit.



Beware of not damaging the power cable when handling the aerator.

Do not bend the cables sharply (the minimum radius of the bend must be more than 5 times the diameter of the cable itself.) The extreme end of the electric cables must never be in contact with water!

If no electric cable is attached to the motor, make sure that the electrical junction box of the motor is closed and sealed against water infiltration.

Prior to starting the unit, after a temporary term of storage, it is necessary to verify the insulation of the windings, by meggering the motor. For any value less than the motor manufacturer recommendation, never start the unit, and call ATB.

6.2. Long term storage (= more than a month)

The same precautions have to be made as in temporary storage, but additionally, in this case, precautions must be taken to avoid damage to motor bearings.

You are requested to rotate manually the motor shaft of the aerator on a monthly basis to prevent jamming or bearing damage. Store the unit in a dry and dust free space.

To prevent condensation on the windings when the motors are stopped for a long time, space heating is required.

- If the motor is provided with anti-condensation heater, it is sufficient to connect it.
- If the motor is not provided with a separate heater, heating is achieved by passing low voltage single-phase power through a transformer on one winding. Before applying this latter solution, please contact ATB.

For a safe storage after previous operation, the product must be thoroughly cleaned. Do never use hydrocarbon-based products for this purpose.

Store the unit in a dry and dust free space.

Prior to starting the unit, after a long period of storage, it is necessary to verify the insulation of the windings. For any value less than the motor manufacturer recommendation, never start the unit, and call ATB.

ENCLOSURE I: Part list HSA aerator with standard stabilization cross

1. Motor with rain cover
2. Motor fastening (bolts + washer)
3. Motor Spacer
4. Cable strain relief
5. Motor flange
6. Flange fastening bolts
7. Flange fastening screw-nut + washer
8. Bolt plate
- 9. Slinger disc
- 10. HELICAL IMPELLER
- 11. Threaded bar
- 12. Impeller fastening (screw-nut + washer)
- 13. Float
- 14. Float-cross fastening (bolts + washer + screw-nut)
- 15. Suction cone with cross plates

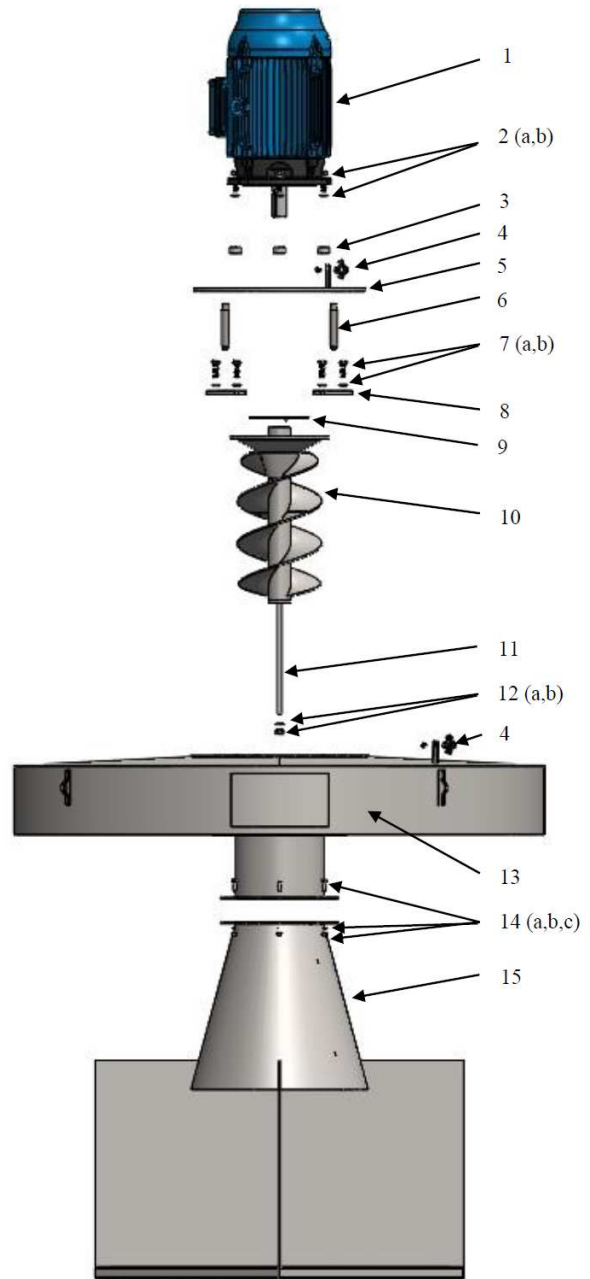

Drawing 20: Exploded view of the ATB HSA with standard stabilisation cross

ENCLOSURE II: Mooring cables and accessories

Usually, there are three anchors, which are equally spread over the periphery of the float.

Use only stainless steel mooring cables, thimbles, clips, quick connectors and if necessary springs.

If cables are included in the order, ATB connects them to the float.

Cable sizes should be as follows:

- 4 mm for units up to 22 kW
- 6 mm for units from 30 kW up to 55 kW
- 8 mm for units above 55 kW

Recommended cable type: 7*19 (7 skeins of 19 wires)

The right method for assembling the thimbles and clips on the cable is as follows:

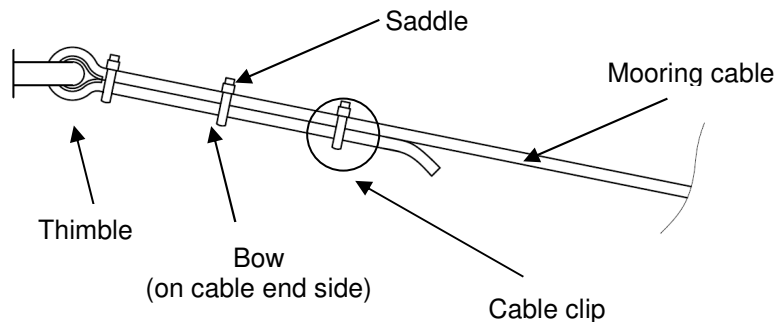

- The thimble is put on the cable in its final position. The cable is bent around the thimble and both cable parts are connected immediately after the thimble by means of clips to leave no space between thimble and cable.
- At least 3 clips should be used for each cable end. The distance between the clips is 3 cm for the 4 mm cable and 6 cm for the 6 mm cable.
- The clips are put on the cable as follows: the bows of the clip on the non-supporting edge (= cable end), the saddle on the supporting edge.
- The clip which is mostly withdrawn from the thimble is fastened first and very tightly, the others are only fastened to prevent movement.
- After fixing the first clip (= the one located the furthest from the thimble), stretch the cable with a load before fixing the 2 other clips.
- The mooring cables should be tightened additionally by mechanical tools, a certain tolerance is required.
- After approximately four weeks, the tightness of the fastening of the clips should be checked again.

We advise you to fasten the clips once a year, since the diameter of the cable diminishes slightly.



Make sure that both the connection of mooring cable to float as of mooring cable to mooring anchor are fastened correctly (quick links completely closed) before start-up.

ENCLOSURE III: General data

MANUFACTURER:

ATB WATER GmbH
Südstr. 2
D-32457 Porta Westfalica
Tel: +49 (0) 5731 30230-0
Fax: +49 (0)5731 30230-30

All unit data (Year of production, Type and Serial Number) is indicated on the identification plate of the device. This information has to be given to ATB in warranty case or for ordering spare parts.

ENCLOSURE IV: Declaration of conformity



DECLARATION OF CONFORMITY

(in accordance with enclosure II B of the Machinery directive)

Manufacturer : ATB WATER GmbH
Südstr. 2
32457 Porta Westfalica
GERMANY

Herewith declares that:

The product : ATB - HSA
High-Speed Surface Aerator

Conforms to

The European Machinery Directives 2006/42/EC.

We hereby declare to be in conformity with the basic safety- and health claims concerning development and production of machinery.

By design, the motors, considered as components, comply with:

- the requirements of the standard EN 60 034 and therefore comply with the provision of Low Voltage Directive 2014/35/EU
- the EMC Directive 2014/30/EU concerning the intrinsic characteristics of emission and immunity levels.

During the design and construction of the aerator, following norms are used:

- EN ISO 12100 : 2011 : Safety of machinery: PART 1: Methodology and PART 2: Technical principles and specifications
- EN 60 034 – concerning safety precautions of electrical machinery

Remark: The machines mentioned above shall not be started until the installation, into which they have been incorporated, has been declared to be in conformity with the Machinery Directive.

This declaration of conformity is invalid if any constructive changes that affect the operating instructions or the technical specifications and/or the intended use have been made to the product.

Porta Westfalica, Germany, 1.03.2018

ATB WATER GmbH
Represented by its Manager
Markus Baumann

A handwritten signature in black ink, appearing to read 'M. Baumann', is written over a horizontal line.

ENCLOSURE VI: Motor O&M manual